

## PRESSURE CAPSULE DETAILS

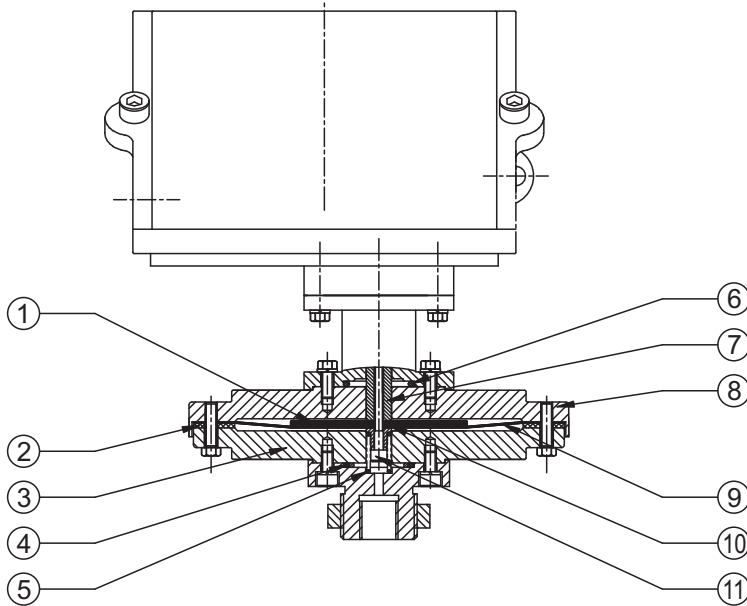

### No. Description

1. Support plate (S.S.)
2. Gasket (Teflon)
3. Bottom flange ( S.S.)
4. Sealing ring (Teflon)
5. Support spring (S.S.)
6. 'O' ring (Nitrile)
7. Transfer pin (S.S.)
8. Top flange (S.S.)
9. Diaphragm (Neoprene)
10. 'O' ring (Viton)
11. Clamping screw (C.S.)

Note : wetted parts are mentioned in italics.

## INSTALLATION DRAWING

