

# MD/MT

# FLANGED PRESSURE SWITCHES



MD



## PRESSURE CAPSULE DETAILS

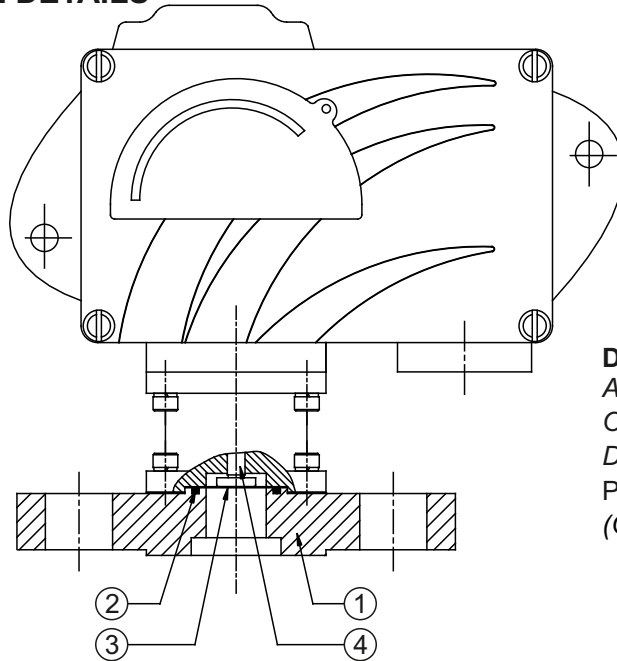

**Description**  
 ANSI 600 Flange (SS316)  
 O-Ring (PTFE®)  
 Diaphragm (PTFE®)  
 Plunger (SS)  
 (Options Available)

Note : *wetted parts* are mentioned in italics.

## INSTALLATION DRAWING

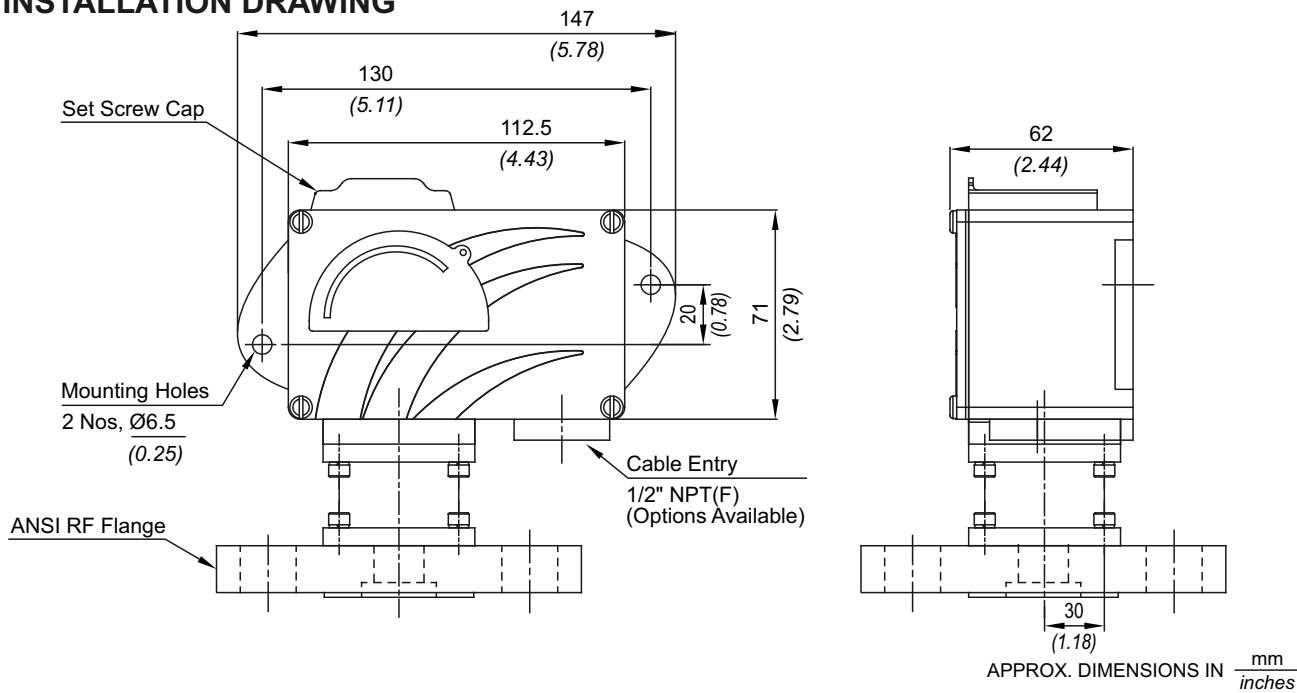

# MD/MT FLANGED PRESSURE SWITCHES

**RANGE SELECTION TABLE**

Range Code	Range bar (psi)	Differential* bar (psi)	Maximum Working Pressure bar (psi)
		Approximate Maximum for "A1" microswitch	
H01	0.1 - 1.0 (1.45 - 14.50)	0.10 (1.45)	As per the class of flange  Please consult Sales Office in case you need clarification on availability of maximum working pressure for a particular range.
H02	0.1 - 1.5 (1.45 - 21.76)	0.12 (1.74)	
H03	0.2 - 2.6 (2.90 - 37.71)	0.15 (2.17)	
H04	0.2 - 3.6 (2.90 - 52.21)	0.20 (2.90)	
H07	0.5 - 7.0 (7.25 - 101.50)	0.40 (5.80)	
H10	0.5 - 10.0 (7.25 - 145.04)	0.80 (11.60)	
H15	1.0 - 15.0 (14.50 - 217.56)	1.00 (14.15)	
H30	5.0 - 25.0 (72.52 - 362.6)	2.00 (29.00)	
H4T	5 - 40 (72.52 - 580.15)	5.00 (72.52)	
H1H	10 - 100 (145.04 - 1450.38)	12.00 (174.05)	
H2H	10 - 200 (145.038 - 2900.76)	24.00 (348.09)	
H4H	40 - 400 (580.15 - 5801.52)	70 (1015.27)	

\* Minimum differential increases with setpoint (Graphs available on request)

\* Differentials of microswitches A2 through A9 will vary. Differentials for A7 are typically twice that for A1 microswitch. Please indicate specifically the differential value in enquiry/order, when it is critical in your application.

**FLANGE CODE TABLE** (Please refer page no. 288 & 289 for more options)

	SS316L		Hastelloy C276		Monel		Titanium		Tantalum	
	RF*	FF*	RF*	FF*	RF*	FF*	RF*	FF*	RF*	FF*
<b>150 #</b>										
1" NB	AC	BS	DI	EY	GO	IE	JU	LK	NA	OQ
2" NB	AF	BV	DL	FB	GR	IH	JX	LN	ND	OT
<b>300#</b>										
1" NB	AI	BY	DO	FE	GU	IK	KA	LQ	NG	OW
2" NB	AL	CB	DR	FH	GX	IN	KD	LT	NJ	OZ
<b>2500#</b>										
1" NB	BM	DC	ES	GI	HY	JO	LE	MU	OK	QA
2" NB	BP	DF	EV	GL	IB	JR	LH	MX	ON	QD

\*RF = Raised Face  
\*FF = Flat Face

**RANGE AVAILABILITY AS PER BORE SIZES**

	H01 to H04	H07	H10	H15	H30	H2T to H2H
1" NB	NA	Yes	Yes	Yes	Yes	Yes
2" NB	Yes	Yes	Yes	Yes	Yes	Yes

# FLANGED PRESSURE SWITCHES

# MD/MT

## HOW TO ORDER INDUSTRIAL FLANGED PRESSURE SWITCHES

Group 1	Group 2	Group 3	Group 4	Group 5	Group 6	Group 7	Group 8
Non standard allocation	Model	Cable Entry Size	Switch Type ANSI flanged	Range Code (values in bar)	Microswitch Type	Flange Size and Material	Diaphragm
<input type="checkbox"/> Reserved for non-standard options not covered in catalogue. Will be given by manufacturer, only after agreement of supply details with customer.	<b>MD</b> = Industrial pressure switch with IP66 rated enclosure as per IS/IEC 60529 <b>MT</b> = Industrial pressure switch with IP66 rated enclosure as per IS/IEC 60529	<b>1</b> = Al. enclosure 1/2" NPT threads <b>*2</b> = Al. enclosure 3/4" NPT threads <b>3</b> = Al. enclosure M20 X 1.5 threads <b>7</b> = SS enclosure, 1/2" NPT threads <b>*8</b> = SS enclosure, 3/4" NPT threads <b>9</b> = SS enclosure, M20 X 1.5 threads	<b>AF1</b> = pressure switch, fixed differential without scale <b>AF2</b> = pressure switch, fixed differential with scale in bar <b>AF3</b> = pressure switch, fixed differential with scale in psi <b>*AA1</b> = pressure switch, adjustable differential without scale <b>*AA2</b> = pressure switch, adjustable differential with scale in bar <b>*AA3</b> = pressure switch, adjustable differential with scale in psi  *Available with A6, A7, A9 & B9 (in group 6) only	<b>H01</b> = 0.1 - 1.0 <b>H02</b> = 0.1 - 1.5 <b>H03</b> = 0.2 - 2.6 <b>H04</b> = 0.2 - 3.6 <b>H07</b> = 0.5 - 7.0 <b>H10</b> = 0.5 - 10.0 <b>H15</b> = 1.0 - 15.0 <b>H30</b> = 5.0 - 25.0 <b>H4T</b> = 5 - 40 <b>H1H</b> = 10 - 100 <b>H2H</b> = 7 - 200 <b>H4H</b> = 40 - 400	<b>A1</b> = General purpose microswitch, rated at 15A; 250 VAC <b>*A6</b> = Adjustable deadband <b>*A7</b> = 2SPDT switching elements <b>*A8</b> = General purpose microswitch <b>*A9</b> = General purpose microswitch <b>*B7</b> = 2SPDT Switching Elements <b>*B9</b> = 2SPDT Switching Elements for adjustable differential  * Please refer to page nos. 290 & 291 for options and specifications of microswitches Please contact sales office for additional information	Please refer to the flange code table on Page nos. 288 & 289 for selection of the flange	<b>0</b> = Neoprene <b>1</b> = PTFE <b>2</b> = SS316L <b>3</b> = Hastelloy C <b>4</b> = Monel 400 <b>5</b> = Titanium <b>6</b> = Tantalum

eg. A high range Industrial/ANSI flanged pressure switch with 1/2" NPT cable entry with fixed differential without scale, having 0.1 bar to 1 bar pressure range, with 15Amp. microswitch, and 2" 150# RF SS316L flange & SS316L diaphragm shall be specified by

Group 1	Group 2	Group 3	Group 4	Group 5	Group 6	Group 7	Group 8
<input type="checkbox"/>	MD	1	AF1	H01	A1	AF	2

Please specify full model number to avoid ambiguity.